

Select from the following:

- 1.0 Components for the installation of a DIAMOND dome in a FLAT ROOF
- 2.0 Installation instructions for a DIAMOND dome in a FLAT ROOF
- 3.0 Assembling the pipe
- 4.0 Fitting the first pipe
- 5.0 Fitting the dome
- 6.0 Alternative components/details for a HEMISPHERICAL dome in a FLAT ROOF
- 7.0 Components for the installation of a DIAMOND dome in a PITCHED ROOF
- 8.0 Installation instructions for a DIAMOND dome in a PITCHED ROOF
- 9.0 Alternative components/details for a HEMISPHERICAL dome in a PITCHED ROOF
- 10.0 Notes on internal arrangements for all PITCHED ROOF installations
- 11.0 Notes on fitting additional extension pipes for all FLAT ROOF installations
- 12.0 Fitting the ceiling diffuser
- 13.0 Installation instructions for a MONOVENT SUNCATCHER

Frequently asked questions

“How long can a SunPipe be?”

A SunPipe can be almost any length that you wish, but loses 10% of light for every metre of SunPipe. For very long SunPipes, a larger diameter should be used. There is a 16% light reduction for every bend. On smaller sizes the total effective maximum length is 8m, and up to 20m on larger sizes.

“What spacing should I use for SunPipes?”

In general terms we recommend 300mm diameter SunPipes at 3 metre intervals, 450mm diameter SunPipes at 4m intervals and 530mm diameter SunPipes at 5 metre spacings.

“Do I need planning permission?”

No, normally it is not necessary to apply for planning permission for the installation of a SunPipe. However, if your property is situated in a Conservation Area then specific permission must be obtained from your Listed Building Officer.

“Are SunPipes suitable for use in a bedroom?”

Yes, but bear in mind that in summer months, due to the efficiency of the SunPipe, your bedroom will be flooded with natural day light first thing in the morning. For this reason, installations in bedrooms or hospital wards can have either a black-out diffuser or a motorised light shut off damper.

“Does the SunPipe require maintenance?”

Due to the shape of the dome, the SunPipe is self-cleaning. The ceiling diffuser fits snugly into the base of the bell end pipe to prevent dust or dirt entering the system and as a result the interior mirror finish surface never requires any maintenance. If however you are fitting a light kit, the bottom ceiling diffuser can be removed but care must be taken not to leave fingerprints on the internal mirror finish of the SunPipe.

“Will the top dome discolour over time?”

The top domes are UV protected and carry a twenty five year guarantee. However, after 10 years there may be a slight clouding of the external surface.

Preparation and safety information

Scaffolding

For flat roofs and single storey buildings not exceeding 10ft. (3m) in height, access to the roof can be gained by ladder, but caution should be taken to prevent any falling materials. For two-storey buildings and pitched roofs a tower scaffold or similar should be provided to gain access to the roof if it is greater than 10ft. (3m) in height from ground level and not more than 20ft. (6m) in height. For access to roofs greater than 20ft. (6m) in height a professionally installed scaffold access should be provided. All scaffolding and ladders must be properly fixed to the building and all necessary precautions must be taken to prevent falling materials and provide a safe working environment for personnel.

Electricity

Normal safety precautions should always be followed. A low voltage power supply should be used when appropriate. Care should be taken to ensure there are no wires, cables, leads, water or gas pipes near the work area. Suitable eye protection and protective gloves must be worn.

Cutting

SunPipe tubes can be sharp after their ends are cut, protective gloves must be worn.

Dust

A safety mask should be worn to ensure you don't inhale dust when carrying out the installation of a SunPipe system.

Other safety recommendations

Don't fit SunPipe when it is raining or the roof area is wet or slippery.

You will need the following equipment:

Protective eyewear, Protective gloves, Protective breathing mask, Ladders, Tin snips, Power drill, Power jig-saw, Dispensing gun to dispense the silicone sealant supplied, Miscellaneous other tools.

1.0 Components for installation of a DIAMOND dome in a FLAT ROOF



Polycarbonate diamond roof dome



Brushed nylon condensation sealing gasket

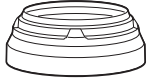

ABS or Galvanised flashing plate and collar

Flat roofs are usually covered in built up felt roofing, asphalt, lead or a proprietary single ply roof covering - such as Sarnifil. For asphalt or hot applied bitumen roofing the galvanised flashing plate will be required. The standard ABS flashing plate will be suitable for other roof types. Whether you have an ABS or galvanised flashing plate, a standard ABS collar is supplied.

Optional additional components

Standard SunPipe 610mm extension length with crimped end

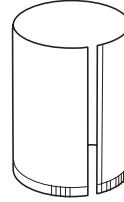

2 section 30°adjustable elbow, used where a small offset is required

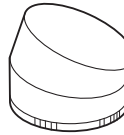

3 section 45°adjustable elbow for large offsets

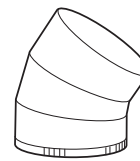

Standard SunPipe 610mm [580mm fitted] plain ends

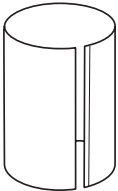

3mm plywood backing panel and marking out template

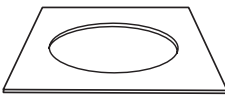

Ceiling trim



SunPipe bell end

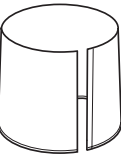

Ceiling diffuser clear or opal



Twist lock on **Diffuser trim**



15 x 15mm self tapping stainless steel screws/washers

5 x for fixing the collar to the flashing plate, 4 x for fixing the pipe to the ABS collar, 5 x for fixing the dome to the ABS collar, 1 x spare



13 x 45mm screws

5 x for fixing the Ceiling diffuser, 8 x for fixing the Flashing plate to roof.

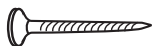

Black washers

5 x for use when fixing the Dome, 5 x for use when fixing the Dome, 5 x for use when fixing the Collar to the Flashing plate, 1 x spare.



Silicone sealant

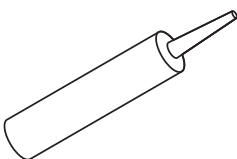

Silver aluminium tape



2.0 Installation instructions for a DIAMOND dome in a FLAT ROOF

2.1 Planning and starting your installation

It's normal to fit the SunPipe between joists
(which are generally at 16" (400mm) centres)

TIPS FOR FINDING JOISTS

Some flat roofs have a narrow ventilation gap or grille, just behind the fascia board running along the edge of the roof (which often supports the rainwater gutter). The joist positions can be seen through the gap.

When you have decided where you would like the SunPipe to be positioned on the ceiling of your room, drill a small pilot hole to determine whether there is sufficient clearance within the ceiling space. For most domestic applications, the SunPipe will fit easily between flat roof joists, it may be necessary therefore to slightly adjust the centre point of the SunPipe location so as to fit between the joists without cutting the joists.

Use the 3mm plywood backing panel as a marking out template and carefully enlarge the hole ensuring that the hole is in the centre of the two joists (the 3mm plywood panel is used later to secure the Ceiling trim). Enlarge your pilot hole to 2" (50mm) in diameter. Check that there are no adjacent power or other services nearby, then enlarge the hole to 6" (150mm) diameter.

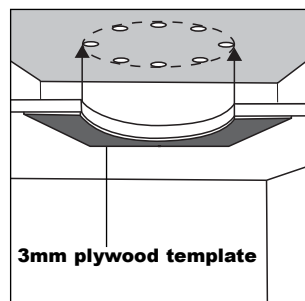

Enlarge the hole to the sizes shown below. Drill directly upwards and through the external roof covering above, eight equally spaced pilot holes inside the perimeter of the ceiling hole.

Roof opening sizes

Nominal SunPipe dia.	Actual dia.	Hole size to cut
300mm 12"	(305mm)	315 mm
450mm 18"	(458mm)	465 mm

Note: 18" Diamond domes will be available from October 2002

What if there isn't enough space to fit your SunPipe between existing rafters or joists?

In most homes SunPipes will fit between existing rafters or joists. However, if there isn't sufficient space, as a guide, on a 'cut roof', one rafter and ceiling joist may be cut to allow installation of your SunPipe but cross trimmers between adjacent rafters or ceiling joists must be installed at each side of the openings to support the 'cut' ends.

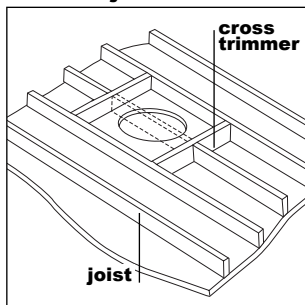

Under no circumstances should any element of a trussed rafter or, on a cut roof, a ridge timber, purlin or binder be cut without prior clearance from a structural engineer.

2.2 Preparatory work outside

Establish whether your flat roof is safe to walk and work on. If it isn't, prepare 'duck-boards' so that you can work safely. Place the flashing plate over the eight pilot holes, aligning the pipe with the holes.

Mark the perimeter of the square plate on the roof, using a felt pen or masking tape. Cut the roof covering back to 2" (50mm) beyond the flashing plate.

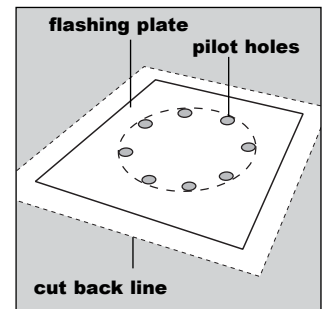

Using the eight perimeter guide holes, cut a circular hole through the roofing board material. The hole must align with the hole in the ceiling below.

Ensure that the surface to receive the flashing plate is clean, dry and free from imperfections. Secure the flashing plate with the 45mm screws provided.

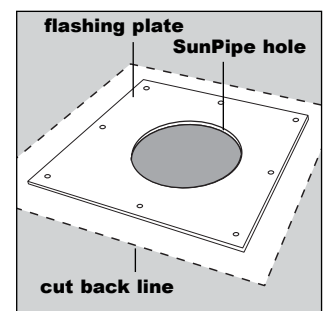

Using felt, asphalt or lead, appropriate to the roof covering you have, form a weatherproof dressing around the flashing plate. Only weatherproof the lower, angled section of the flashing plate, up to a height of 5" (140mm). Don't weatherproof on the upper vertical section of the flashing plate as it will obstruct the fitting of the ABS collar described later.

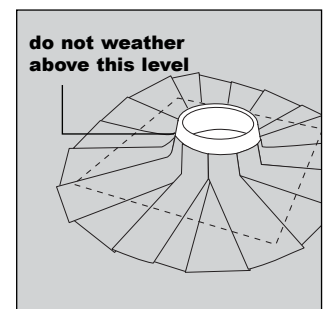

2.3 Fitting the collar

Once the flashing plate is secure and the weatherproof dressing finished, sit the ABS collar onto the flashing plate.

Drill five equally spaced holes around the collar in the positions shown adjacent and fit the 15mm self tapping screws and washers supplied. Note, the screw positions are different, depending on which flashing material you are using.

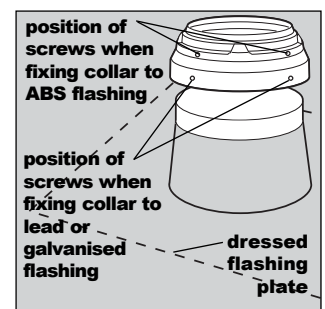

Apply silicone sealant over the screws/washers to form a weatherproof seal.

3.0 Assembling the pipe

Lie the pipe on its side with the seam uppermost. It is important that the protective film should be left on the inside surface of the pipe until later. This protects the pipe from dirty finger marks and also stops dust or dirt getting on the surface of the pipe. However, carefully run a Stanley knife down the joint where the protective film is attached to the inside of the pipe so as to be able to release the film later without too much difficulty.

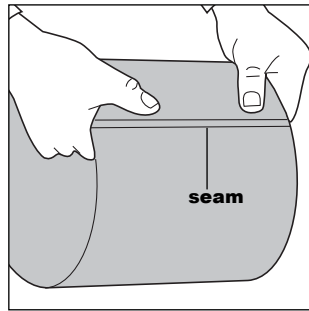

Align the ends of the pipe. The special seams clip into one another forming a locking action. Put pressure on the seam all along its length to ensure the seal is secure. Apply a length of aluminium tape over the made joint.

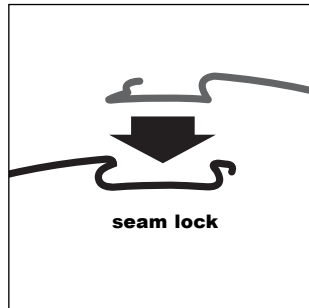

3.1 Trimming the pipe to length

For Flat Roof Applications

Measure the distance from the top of the collar to the underside of your ceiling.

The pipe should project 5mm above the collar and be cut approximately 50mm above the room's ceiling.

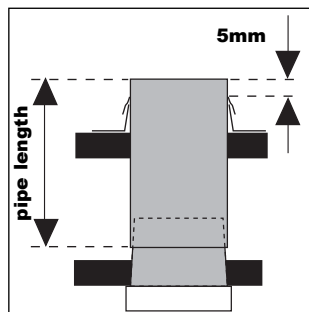

For Pitched Roof Applications

Trim the top (plain end) of the pipe after passing through the flashing, to leave a 5mm upstand. Please also refer to Section 10 for assembling the pipe internally which will dictate the exact length of pipe to pass through the flashing before connecting up to the adjustable elbow in Section 10.

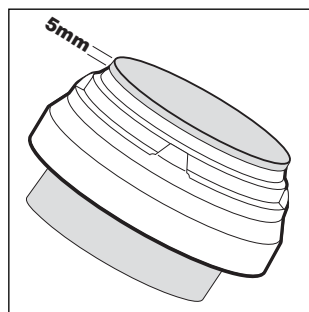

4.0 Fitting the first pipe

Insert the topmost pipe into the ABS flashing plate from underneath. If fitting to a pitched roof or using additional lengths in a flat roof application, the crimped end should be at the bottom end of the pipe.

Allow the pipe to project 5mm through the top of the collar. Secure the pipe in position using four of the 15mm self tapping screws and washers supplied.

Once the pipe is fixed in position, carefully wipe the top of the outer surface of the SunPipe to remove any moisture, dirt or finger marks, etc. and apply a thick bead of silicone sealant, to seal between the SunPipe and the ABS collar, and then allow to dry.

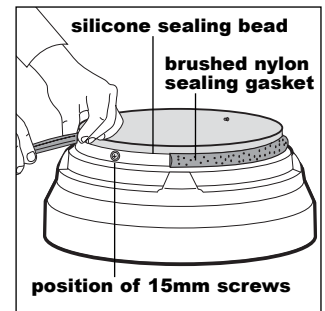

This is the most important part of the Sun Pipe installation since this silicone sealant will prevent any rain or condensation from running down the outside of the SunPipe which may create a water stain on the ceiling.

Carefully apply the brushed nylon sealing gasket to the projecting part of the top of the collar and over the screws securing the pipe to the collar. The gasket should be level with the top of the ABS collar. This gasket seals the SunPipe against ingress of dirt or insects but still allows the SunPipe to 'breathe', thereby preventing any later problems of condensation.

5.0 Fitting the dome

Before attaching the top dome to the collar/upstand, peel the protective film from the top rim of the first pipe and push it down the pipe, just enough to form a protective 'plug' in the pipe.

Align the pre-drilled holes on the dome with the lugs on the collar/upstand. Secure the roof dome to the collar/upstand using the 15mm self tapping screws and washers supplied. Take care not to scratch the dome when positioning it. All external works are now complete.

Carefully brush down the roof covering and all flashing to remove any particles of dust or dirt. Ensure that the dome is free from any finger marks, dust or dirt.

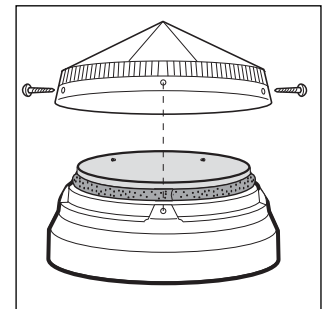
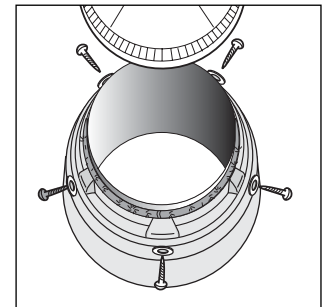

Note: When the SunPipe is initially installed, particularly in winter months, the air contained within the SunPipe tube does contain moisture and it is quite common therefore to see beads of condensation forming on the inside of the SunPipe dome immediately after installation. This is quite normal and the design of the SunPipe dome is such that this condensation will run down the inside of the dome, into the condensation gasket and will dry out naturally.

Internal installation

Please Refer to Section 10 or 11 depending on your particular type of application or Section 12 for fitting the ceiling diffuser

6.0 Alternative components/details for a HEMISPHERICAL dome in a FLAT ROOF

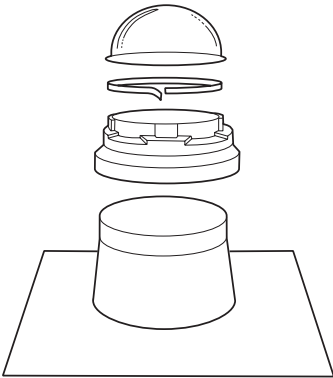

Polycarbonate roof dome

Brushed nylon condensation sealing gasket

ABS or Galvanised flashing plate and collar

Flat roofs are usually covered in built up felt roofing, asphalt, lead or a proprietary single ply roof covering - such as Sarnafil.

For asphalt or hot applied bitumen roofing the galvanised flashing plate will be required. The standard ABS flashing plate will be suitable for other roof types. Whether you have an ABS or galvanised flashing plate, a standard ABS collar is supplied.

Alternative details for a HEMISPHERICAL dome in a FLAT ROOF

Firstly, carefully follow the instructions as set out in Section 2 of these Instructions, the other information you will need to know is as follows:

Roof opening sizes

Nominal SunPipe dia.	Actual dia.	Hole size to cut
200mm 8"	(216mm)	225 mm
330mm 13"	(330mm)	340 mm
450mm 18"	(458mm)	465 mm
530mm 21"	(533mm)	545 mm
600mm 24"	(610mm)	630 mm
750mm 30"	(762mm)	780 mm
900mm 36"	(914mm)	935 mm
1000mm 40"	(1000mm)	1030 mm

The only other alternative detail you will need to know for fitting the first pipe length (if you have one of the earlier collars which have only two rings above the angled bevel) is as follows:

Measure the distance from the top of the collar to the underside of your ceiling.

The pipe should project 15mm above the collar and be cut approximately 50mm above the room's ceiling.

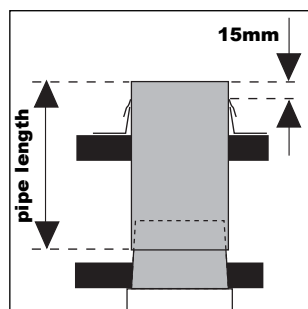

6.1 Fitting the first pipe

Please refer to section 4.0 with the following exceptions:

Allow the pipe to project 15mm through the collar.

Apply the brushed nylon sealing gasket to the outside of the SunPipe which is projecting above the collar.

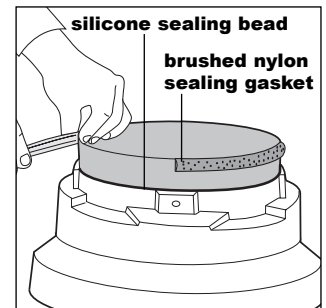

Note: On the new generation of SunPipe collars, the collar will be supplied with an upstand to receive the brushed nylon sealing gasket which should be applied to the top of the collar. When applying the silicone sealant, take particular care not to get the sealant on the brushed nylon.

Now please refer to section 5.0 for fitting the dome

7.0 Components for the installation of a DIAMOND dome in a PITCHED ROOF

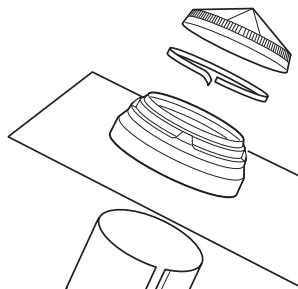

Polycarbonate roof dome

Brushed nylon condensation sealing gasket

ABS flashing plate and collar for slate roofs

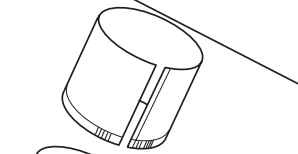

SunPipe connecting piece [cut to length on site]

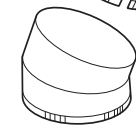

2 section 30° adjustable elbow [required for roof slope upto 30°]

3 section 45° adjustable elbow [required for steeper roof slopes up to 45°]

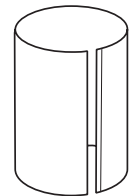

Standard SunPipe 610mm [580mm fitted] plain ends



3mm plywood backing panel and marking out template

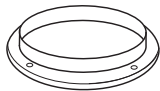

Ceiling trim

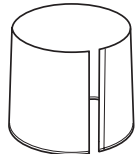

SunPipe bell end



Ceiling diffuser clear or opal



Twist lock on Diffuser trim



15 x 15mm self tapping stainless steel screws/washers

5 x for fixing the collar to the flashing plate, 4 x for fixing the pipe to the ABS collar, 5 x for fixing the dome to the ABS collar, 1 x spare



13 x 45mm screws

5 x for fixing the Ceiling diffuser, 8 x for fixing the Flashing plate to roof.



Black washers

5 x for use when fixing the Dome, 5 x for use when fixing the Dome, 5 x for use when fixing the Collar to the Flashing plate, 1 x spare.

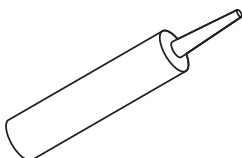

Silicone sealant



Silver aluminium tape

Alternative components

ABS flashing plate, and lead skirt for flat tiled roofs.

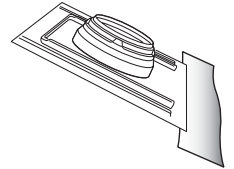

Vertical SunPipe flashing plate in galvanised steel, for slate roofs.

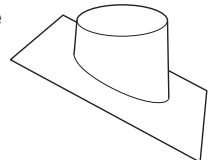

Lead flashing plate, for bold rolled tile roofs.

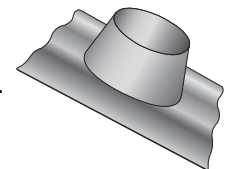

ABS collar

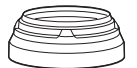

Optional additional components

Standard SunPipe 610mm extension lengths with crimped ends.

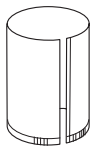

2 section 30° adjustable elbow, used where a small offset is required.

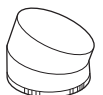

3 section 45° adjustable elbow for large offsets

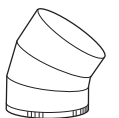

8.0 Installation instructions for a DIAMOND dome in a PITCHED ROOF

8.1 Before you start work

It's safer to fit the SunPipe between rafters

Most pitched roofs are constructed using the 'Cut Roof' or the 'Trussed Rafter' method. In newer buildings, trussed rafters are more common.

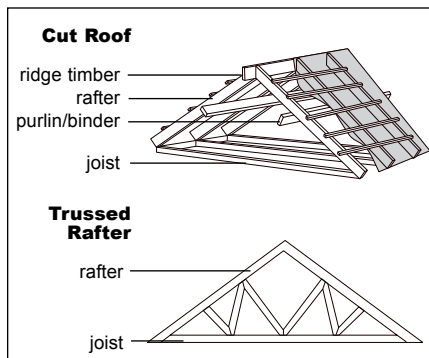

What if there isn't enough space to fit your SunPipe between existing rafters or joists?

In most homes SunPipes will fit between existing rafters or joists. However, if there isn't sufficient space, as a guide, on a 'cut roof', one rafter and ceiling joist may be cut to allow installation of your SunPipe but cross trimmers between adjacent rafters or ceiling joists must be installed at each side of the openings to support the 'cut' ends.

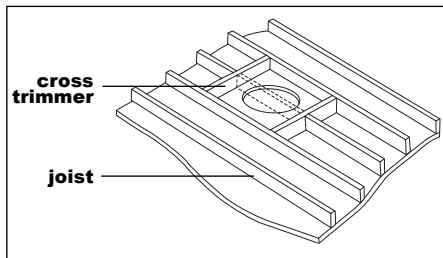

Under no circumstances should any element of a trussed rafter or, on a cut roof, a ridge timber, purlin or binder be cut without prior clearance from a structural engineer.

8.2 What's the best location for a SunPipe?

The most efficient place for your SunPipe is on a south facing roof slope. Always locate it as near to the ridge as possible. Try to avoid sheltered or concealed areas of your roof since the SunPipe will not benefit from direct sunlight.

In these circumstances the amount of light produced by the SunPipe which is in the shadow of the roof, will be similar to the amount of light obtained from a normally installed SunPipe on an overcast day.

There are a variety of views on the best position for a SunPipe on a north facing roof. Previously our advice was to fit a vertical flashing on a north facing roof. However, our experience indicates that on a north facing roof, whether the SunPipe is vertical or perpendicular to the roof surface, there is very little difference in performance and therefore we do not normally recommend the use of a vertical SunPipe. The only exception is where a SunPipe can be positioned near to the ridge, where a vertical application would enable the SunPipe to catch a certain amount of direct sunlight. Otherwise we recommend the compact flashing with an elbow used internally as for any other SunPipe application.

8.3 Preparing for your particular roof type

SunPipes are suitable for virtually any type of roof covering but these instructions are particularly written for slate or tiled roofs.

For thatched roofs or other unusual roof coverings, please call our technical department on 01494 897705.

For SunPipe installations near the ridge of steep north facing **slate** roofs it is advisable to use the vertical SunPipe **galvanised flashing plate**.

Only for installations near the ridge of steep north facing, **plain tile or bold roll tiled** roofs it is advisable to use the vertical SunPipe **lead flashing**, details of which are set out later. Otherwise, for most north facing roof slopes, it is still advisable to use the **lead flashing** in the perpendicular form.

For **metal profile** or **asbestos** roofs, a **moulded GRP** or **aluminium** flashing plate can be used, see 'Other products'.

8.4 Preparatory work outside

From a secure and stable ladder or fitted loft ladder, enter the loft. The floor areas in some lofts are not safe to walk on. Use temporary boards to span between the joists if this is the case. Look carefully at the area where you want to install your SunPipe. Make sure there are no obstructions to the installation such as water tanks, pipes, electrical cables, etc. Determine where you want the SunPipe to come into the loft from below and where you want it to exit through the roof.

Drill a small pilot hole (midway between two rafters) through the internal roofing structure, and out through the external roof covering. Place a timber dowel or similar marker through the hole, (which will make it easier to see when you are outside). You will eventually need to enlarge the hole to the size shown in the following table.

Roof opening sizes

Nominal SunPipe dia.	Actual dia.	Hole size to cut
300mm 12"	(305mm)	315 mm
450mm 18"	(458mm)	465 mm

Note: 18" Diamond domes will be available from October 2002

8.5 Preparatory work inside

Establish the position in which the SunPipe is to be installed by locating the dowel inserted from inside. Remove the slates or tiles from around the area. Set the slates or tiles aside. Temporarily place the flashing plate in position so that it is centred over the pilot hole. Remove sufficient tiles to mark and cut back the battens and cut diagonals in the felt covering to allow for the installation of the pipe. Refer to section 8.4 above to determine the size of the hole to mark.

It is important to push up a length of the SunPipe from the inside of the roof, through the felt, so that the slits or cuts (as shown) secure the side of the SunPipe and trap the felt in position.

You can either cut the tiles above the ABS flashing collar or leave them uncut. This depends on whether you have the tools available for cutting roof tiles and where the collar is located in relationship to the first row of tiles above the collar. Place the tiles in position to make sure they fit.

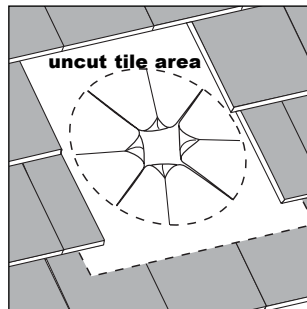
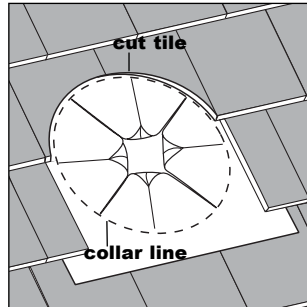

8.6 Fitting the flashing plate on a slate roof

When fitting a SunPipe in a slate roof, the ABS flashing provides sufficient weatherproofing, you don't need any extra lead flashing. Therefore the ABS flashing plate should be tucked under the row of slates above, interleaved with the slates on each side and sit on top of the row of slates below. Use the 45mm long screws which are supplied, to fix the ABS flashing plate to the roof battens.

Wherever possible, align the bottom edge of the ABS flashing with the bottom edge of a row of slates. Cut the slate both sides of the bottom edge of the ABS flashing so that everything lays flush.

Then re-lay the next row of slates carrying the slate over the ABS flashing but stopping 25mm short of the SunPipe upstand collar.

The third row of slates should then be carried over so as to weather the top edge of the ABS flashing.

With some natural or man-made slates which are more than 5mm in thickness, it is advisable to use the lead skirt as set out in the following paragraphs.

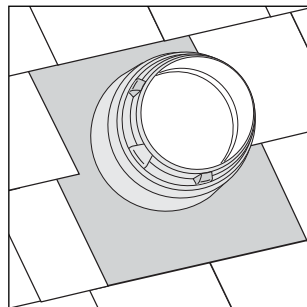

8.7 Fitting the flashing plate on a tiled roof

When fitting SunPipe in a plain tiled roof you should use the lead skirt. When fitting a vertical SunPipe, you should be using a lead flashing and ABS collar. Installation of the lead flashing unit is described later.

Temporarily remove the tiles around the area in which you are going to fit the flashing plate. The ABS flashing is supplied with a self adhesive bitumen strip on its underside, to fix the lead skirt. The adhesive is protected by a strip of paper which should only be removed when you are ready to fit the skirt.

Lay the lead on a flat surface and clean off any dirt or dust. Take the ABS flashing and carefully remove the protective paper and then place it firmly on top of the lead skirt, allowing the lead skirt to overlap by approximately 50mm to the underside of the ABS flashing. Press down firmly to ensure that the bitumen strip adheres to the lead. Secure it with three pop rivets, one in the centre and one at each end.

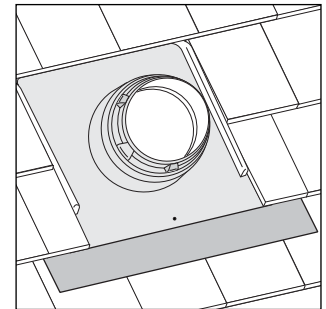

Carefully position the ABS flashing (with its lead skirt attached) taking care that it is over the centre of the hole that you have already prepared. Fix down the ABS flashing plate to the roof battens using the 45mm screws supplied. Make sure that you use two screws in line with the bottom edge of the ABS collar but to the edge of the upstand. This will pull the ABS flashing down on to the batten allowing the correct alignment of the roof tiles.

8.8 Fitting a vertical Sunpipe on a slate roof

The basic principles are the same as described above. A lead skirting is not normally required, but with some natural or man-made slates which are greater than 5mm in thickness, it is advisable to use one.

Please refer to Section 8.2 regarding the use and location of vertical SunPipes

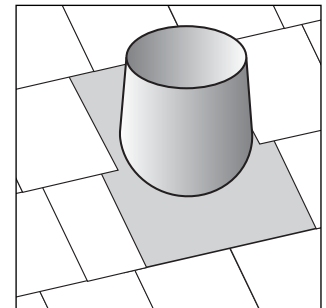

8.9 Fitting a lead flashing on bold rolled tiles

For bold rolled tiled roofs a Code 4 lead flashing plate can be supplied. It is supplied with the sides rolled for transportation. These should be un-rolled and dressed to the roof surface. It should be dressed under the row of tiles at the top edge of the lead and over the row of tiles at the bottom of the lead. Sit the ABS collar onto the lead.

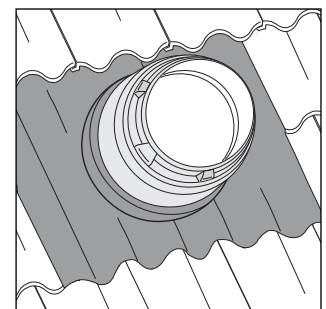

Now please refer to: Section 2.3 for fitting the collar, or section 5.0 for fitting the dome since the fitting of the collar and dome to a lead flashing used in this way is similar to the fitting of a common dome on a flat roof flashing.

9.0 Alternative components for a HEMISPHERICAL dome in a PITCHED ROOF

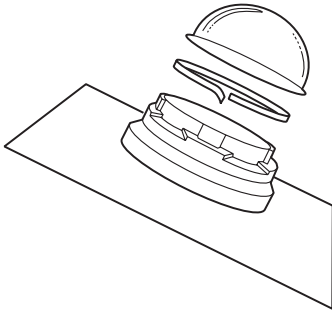

Polycarbonate roof dome

Brushed nylon condensation sealing gasket

ABS flashing plate and collar for slate roofs

Alternative components

ABS flashing plate, expanding foam tape and lead skirt for flat tiled roofs. Expanding tape shown as dotted line.

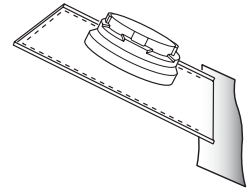

Alternative instructions for a HEMISPHERICAL dome in a PITCHED ROOF

Roof opening sizes

Nominal SunPipe dia.	Actual dia.	Hole size to cut
200mm 8"	(216mm)	225 mm
330mm 13"	(330mm)	340 mm
450mm 18"	(458mm)	465 mm
530mm 21"	(533mm)	545 mm
600mm 24"	(610mm)	630 mm
750mm 30"	(762mm)	780 mm
900mm 36"	(914mm)	935 mm
1000mm 40"	(1000mm)	1030 mm

Note: The Alfes expanding foam expands slower at lower temperatures.

Temperature	Expanding time
0°C	62 hours
10°C	21 hours
20°C	26 minutes
30°C	6 minutes

It is NOT necessary to use expanding tape with a slate roof. The removed tiles must be replaced into their final position quickly, to the top and the sides of the flashing plate. The expanding tape will expand to fill any gap that remains between the flashing plate and the underside of the tiles. This expanding foam tape prevents any water ingress between the flashing and the underside of the tiles and has an Agrément Board Certificate, with a 25-year guarantee

Use the expanding tape on any tiled roof where an ABS flashing plate is used

When you have fitted the flashing plate, carefully clean the top and two sides of the flashing plate to remove any dust or dirt and then apply the expanding foam tape to these three edges. The expanding tape comes compressed to approximately 5mm thickness when wrapped, but expands rapidly to approximately 20mm thickness when exposed to the air.

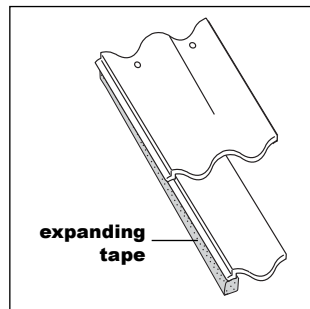

Care should be taken NOT to unwrap the expanding foam tape until you are ready to use it.

9.1 Fitting the first pipe

Please refer to Section 4.0 with the following exceptions:

Allow the pipe to project 15mm through the collar.

Apply the brushed nylon sealing gasket to the outside of the SunPipe which is projecting above the collar.

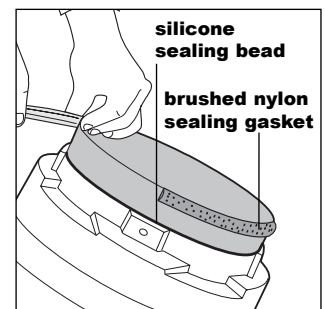

Note: On the new generation of SunPipe collars, the collar will be supplied with an upstand to receive the brushed nylon sealing gasket which should be applied to the top of the collar. When applying the silicone sealant, take particular care not to get the sealant on the brushed nylon.

Now please refer to Section 5.0 for fitting the dome

10.0 Notes on internal arrangements for all PITCHED ROOF installations

Push in the two or three section elbow, (2 section for 30° pitch roofs, 3 section for 45° pitch roofs), adjusting it by rotating the sections to achieve the correct angle so that the tube points vertically downwards.

Now peel off the coloured protective film down the pipe carefully, allowing it to form a descending 'plug' which prevents dust or dirt getting into the pipe whilst the installation is being completed.

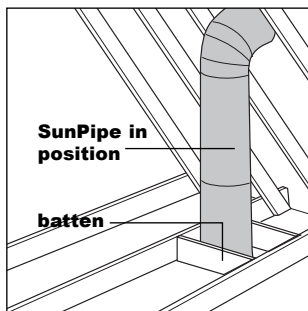

Ensure that all of the protective film is removed from the previous pipe or elbow just before attaching the next section

The second straight section of pipe should then be assembled as previously described and the two (or more) pipes connected together. Once you are satisfied that the angle and the location of the tubes are correctly aligned to pass through the loft space, continue as above with third or fourth sections and further elbow joints, depending on the distance you are spanning.

When you are satisfied that the angles and connections are all correct, drill small guide holes on each side of the SunPipe tube and screw the joints together with remaining self tapping screws. The silver aluminium tape supplied should be used to seal the joints against dust and dirt.

For best results, silicone-caulking seal should be applied to all joints before connecting, screwing and taping. On long unsupported lengths of pipe, additional fixing screws can be used to fix the SunPipe to any adjacent joist or rafter.

Having established the entry point of the SunPipe into the room below, use the 3mm ply backing panel as a template to mark out the opening. Then use a pad saw or similar to carefully cut out the opening. The 3mm ply backing plate should then be placed in the ceiling space over the hole to provide extra support to the ceiling diffuser.

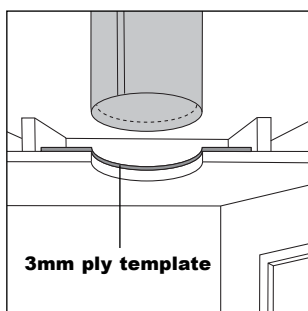

11.0 Notes on fitting additional extension pipes for all FLAT ROOF installations

Fit additional straight lengths to suit your particular roof void. The crimped ends are slightly smaller than the plain ends. The crimped ends fit tightly into the plain ends. If there is a large void between the ceiling of your room and the flat roof, you may need to connect additional pipes together. Alternatively you may want to create an offset. This is when the SunPipe has two elbow sections. This can enable the SunPipe to enter the room in a location which is not directly underneath where it exits through your roof. Rotating the elbow sections can achieve different angles. Where a small offset is required, two 30° elbows can be used, where a sharp offset is required 45° elbows should be used.

Now peel off the coloured protective film down the pipe carefully, allowing it to form a descending 'plug' which prevents dust or dirt getting into the pipe whilst the installation is being completed.

Ensure that all of the protective film is removed from the previous pipe or elbow just before attaching the next section

When you are satisfied that the angles and connections are all correct, drill small guide holes on each side of the SunPipe tube and screw the joints together with remaining self tapping screws. The silver aluminium tape supplied should be used to seal the joints against dust and dirt. Now peel off the coloured protective film down the pipe carefully, allowing it to form a descending 'plug' which prevents dust or dirt getting into the pipe whilst the installation is being completed.

For best results, silicone-caulking seal should be applied to all joints before connecting, screwing and taping. On long unsupported lengths of pipe, additional fixing screws can be used to fix the SunPipe to any adjacent joist or rafter.

12.0 Fitting the ceiling diffuser

To avoid any possibility of eye damage, be careful not to look upwards through the SunPipe. The efficiency of the unit is such that even in dull light, eye damage could result.

The bottom of the SunPipe tube should be trimmed back so that it is approximately 50mm above the top of the ceiling. Insert the 3mm plywood backing panel in the ceiling space over the hole to provide extra support to the ceiling diffuser (you may have to cut it in two if you have limited access to the ceiling space).

The ceiling trim can now be screw fixed to the ceiling. Use five of the 45mm screws supplied. Don't forget to remove any residue of the pipe's protective lining. Once the ceiling trim has been fixed into place, the bell end can be inserted into the bottom of the Sunpipe.

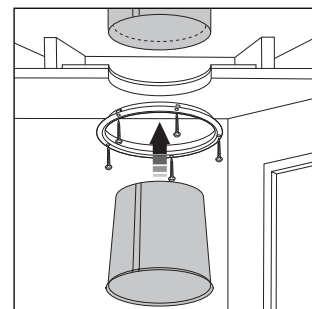

The ceiling diffuser is designed to push fit into the bottom of the bell end pipe. Push the diffuser trim over the ceiling diffuser and twist lock it anti-clockwise to secure it in place.

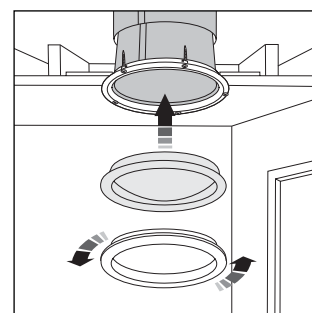

13.0 Installation instructions for a MONOVENT SUNCATCHER

There are two types of Monovent SunCatcher, the ABS 350 and ABS 550. The installation procedure will apply equally to both sizes and these instructions are suitable for flat or pitched roof applications.

13.1 Flat roof

Follow the procedure as set out in Section 2.0 of this installation booklet.

An opening needs to be formed through the flat roof of either 320mm (for the ABS 350) or 520mm (for the ABS 550).

Both systems are designed to be installed without the necessity of cutting any structural timbers but as set out in Section 2.1, it may be necessary to trim just one flat roof joist.

13.2 Pitched roof

Follow the procedure as set out in Sections 8.1 - 8.9 of this installation booklet for installing the flashing plate.

13.3 Assembling the SunPipe

Follow the procedure as set out in Sections 9.1 and 10.0, for installing the SunPipe through the unit at roof level but do not connect the elbows at this stage.

13.4 The internal flexible duct

Take the flexible duct from the box and carefully attach it to the downstand of the projecting galvanised duct tied up in its compact condition at this stage, (marked a on the adjacent sketch).

Offer up the bottom section of the Monovent duct to the ceiling and carefully mark around with a felt-tip pen or similar in its required location having regard to Section 12.0. Cut out the section of the ceiling.

Offer up the bottom section (marked b on the adjacent sketch) and push up so that fixing lugs are flush with ceiling level. Drill and fix bottom section into adjacent ceiling joists, inserting additional timber battens if necessary.

Once the bottom section is secure, complete the SunPipe installation using the adjustable elbows and extension lengths, all as set out in Section 10.0. Release the flexible duct stays and fix flexible duct over the metal duct at ceiling level, fix the clear diffuser to the projecting lugs and clip into place the adjustable ventilator. On the ABS 550 Monovent SunCatchers, the ceiling ventilation is a 600mm square white egg-crate grill with manual adjustable dampers. You will need to form a 570 x 570 hole through the ceiling, fit the back box and ceiling diffuser to the SunPipe.

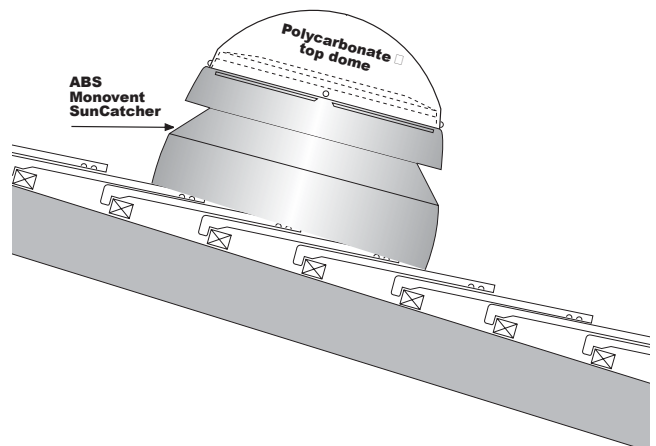
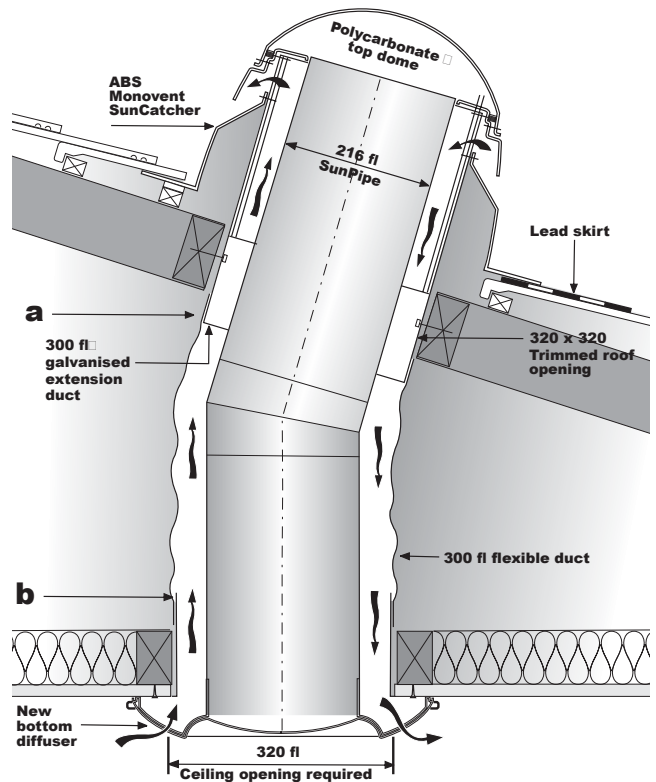
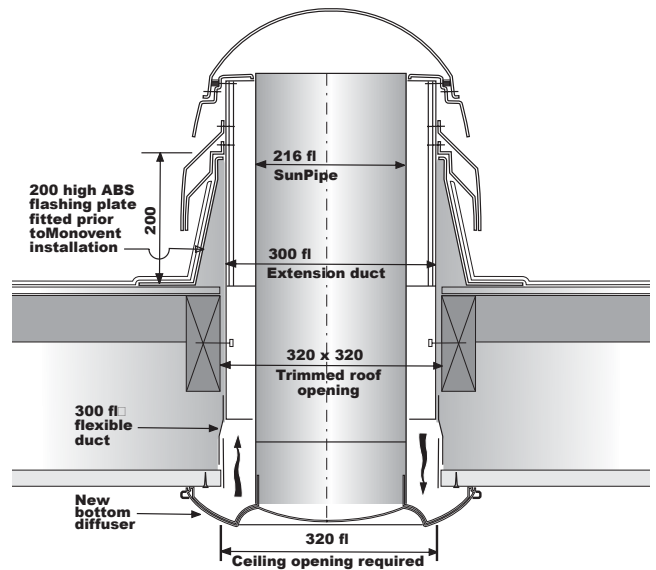

When the installation is complete

Please leave these installation instructions with the owner of the SunPipe or Monovent Suncatcher. This will enable them to carry out the straightforward maintenance mentioned below.

Maintenance

The SunPipe is designed to be maintenance free and the shape of the dome and the flashing is designed to be self-cleaning. If for any reason, further cleaning is required, only warm, soapy water should be used to wash the external dome and flashing. Take great care not to scratch the dome when washing. Internal cleaning should not be required since all components are effectively 'sealed-for-life'.

SunPipe has a 25 year guarantee against any defects arising due to faulty materials.

Other products

Low voltage electric light kit

Where a single light source is required, such as at the top of a staircase or landing etc., the SunPipe can be fitted with a 50 Watt low voltage light fitting that has been specially designed so as not to affect the natural light output during daytime use. A transformer is supplied with the kit, which should be fitted in accordance with the instructions supplied. The lighting kit should be fitted approximately 12" (300mm) above the ceiling level, thus giving an even spread of light into the ceiling diffuser. The electrical connection should be made by a qualified electrician. Should the light bulb need to be replaced, the ceiling diffuser will need to be taken down for access to the light fitting. The twist lock ceiling trim should be turned anti-clockwise, so as to release the trim, and the bottom diffuser can then be easily prised off with a small screwdriver. Once you have changed the light bulb, carefully wipe down the mirror-finish surface, so as to remove any finger marks, gently wash or wipe out the ceiling diffuser to remove any particles of dust and then clip back into position. The ceiling trim can then be re-applied with an anti-clockwise twist lock turn.

Flashing plates for profiled roofs

A custom flashing plate can be made to the profile of your particular roof. We will approach this type of installation in several ways, depending on your roofing material.

For aluminium profiles we will carry out a site survey and cut and weld on site the necessary aluminium flashing and upstand, complete with all the necessary internal trimmers,

internal closing plates, hard pack insulation, all welded on site and provided with a 25-year guarantee. For colour coated metal roofs we will site measure and make up a purpose made GRP flashing and upstand which is fitted from the underside.

The roof is then prepared, primed, bonded and in-situ GRP is applied. An alternative method is galvanised oversheeting which can be fitted and weatherproofed over an existing roof surface.

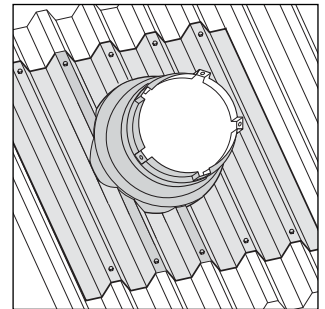

SunPipe @ Monodraught

SunPipe @ Monodraught Limited,
Halifax House,
Cressex Business Park,
High Wycombe,
Bucks HP12 3SE

Tel: 01494 897705 Fax: 01494 532465
www.sun-pipe.info
email: sunpipe@monodraught.com